



Please read this manual carefully before use this product.

PowMr®
Website: Support@powmr.com
Email: www.powmr.com

User's manual

Contents

- 1. Warranty-----1
- 2. Safety instructions and waiver liability-----2
 - 2.1 safety instructions-----2
 - 2.2 Liability Disclaimer-----2
- 3. Overview-----3
- 4. Dimensions-----4
- 5. Installation-----4
 - 5.1 Installation Notes-----4
 - 5.2 Air Circuit Breaker installation-----4
- 6. Operation-----6
 - 6.1 LCD display-----8
 - 6.2 Working mode-----9
 - 6.3 Batteries charge voltage reference-----9
 - 6.4 Manual Setting-----9
- 7. Troubleshooting , Protections-----11
 - 7.1 Troubleshooting-----11
 - 7.2 Protections-----12
- 8. Technical Data-----13
- 9. Content Included-----14

MPPT 30A/ 40A/ 50A/ 60A Solar Charge Controller User's manual

Dear Customers,
Thanks for choosing the MPPT series solar charge controller. Please take time to read this user manual, it will help you to make full use of many advantages the controller can provide your solar system.

This manual gives important recommendations for installing and using and so on. Read it carefully in your own interest and pay attention to the safety recommendations in it please.

1. Warranty

Thank you very much for using our controller. According to the prescription, any damaged unit caused by the user's failure to install, disassemble or incorrect use of this product may provide maintenance.

1.1 Warranty regulations:

- 1) within 30 days from the date of purchased, the faulty controller will be free to be replaced the under normal using (with the authorized technical personnel authorized by the company).
- 2) within 2 years from the date of purchased, the faulty controller will be free to be repaired.

Notes: Disassembled privately, no warranty

User's manual

2. Safety instructions and waiver liability

2.1 Safety instructions

Be aware that only qualified professionals could install these controllers. Please read all manuals before installing them.

- 1) Keep controller away from water. Don't use wet towel to wipe controller.
- 2) Keep controller in an environmental temperature from -22°C ~ +55°C. Avoid direct sunlight.
- 3) Keep good heat dissipation.
- 4) Use the pure copper wires and connect all polarity correctly.
- 5) The load output is only for DC load less 5A current.
- 6) Please don't set any parameters if you are not professional since the controller can work fine in default condition except lithium battery.

2.2 Liability Disclaimer

The manufacturer shall not be liable for damages, especially on the battery, caused by use other than as intended or as mentioned in this manual or if the recommendations of the battery manufacturer are neglected. The manufacturer shall not be liable if there has been service or repair carried out by any unauthorized person, unusual use, wrong installation, or bad system design.

3. Overview

MPPT series solar charge controller is based on an advanced maximum power point tracking (MPPT) technology developed, dedicated to the solar system, the charge controller conversion efficiency up to 97%.

It comes with a number of outstanding features, such as:

- ① MPPT 30A/40A/50A/60A solar charge controller
- ② 100% MPPT technology
- ③ Built-in DSP controller with high performance
- ④ Automatic switch for 12V/24V/36V/48V battery bank
- ⑤ 3-stage charging optimizes battery performance
- ⑥ Overcharge protection, Input PV polarity reverse protection, Output limited current protection, Over-temperature protection
- ⑦ Troubleshooting promotion function.
- ⑧ Suitable for battery types such as sealed lead acid, vented gel and lithium battery, etc
- ⑨ Easy to be mounted

User's manual

4. Dimensions

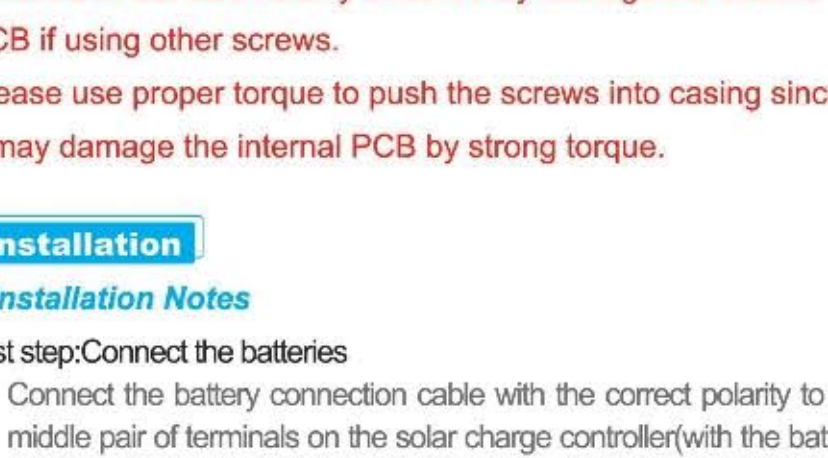

Notes:
Please use our screws only since it may damage the internal PCB if using other screws.
Please use proper torque to push the screws into casing since it may damage the internal PCB by strong torque.

5. Installation

5.1 Installation Notes

▲ 1st step: Connect the batteries

Connect the battery connection cable with the correct polarity to the middle pair of terminals on the solar charge controller (with the battery symbol). If the system is 12V, please make sure your battery voltage more than 12V, then the controller can boot up.

▲ 2nd step: Connect the solar panel

Ensure that the PV modules is protected from incident light. Ensure that the solar panel doesn't exceed the maximum permissible input current. Connect the PV modules connection cable to the correct polarity of the left pair of terminals on the solar charge controller (with the PV modules symbol).

▲ 3rd step: connect loads

Connect the load cable to the correct polarity of the right pair of terminals on the solar charge controller (with the lamp symbol). To avoid any voltage on the wires, please connect the wire to the load before connect to the controller.

▲ 4th step: Final worked

Tight all cables connected to the controller and remove all the debris around the controller (leaving a space of approx. 5.91in).

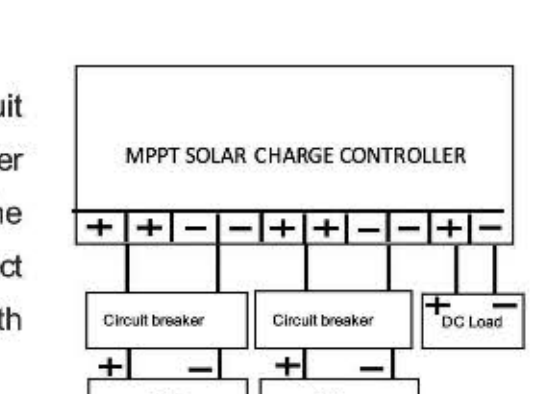

Notes:
When the reading data of PV or Battery is constantly changing, don't worry about it. The controller is finding MPP point. It's caused by your PV input power or voltage isn't enough. Please contact us soon. Our technological team will assist you.

User's manual

5.2 Air Circuit Breaker installation

We strongly recommend connecting a fuse directly to the battery to protect any short circuit at the battery wiring. Solar PV modules create current whenever light strikes them. The current created varies with the light intensity, but even in the case of low levels of light, full voltage is given by the modules. So, protect the solar modules from incident light during installation. Never touch uninsulated cable ends, use only insulated tools, and make sure that the wire diameter is in accordance with the expected currents of solar charge controller. Connections must always be made in the sequence described below.

Air Circuit Breaker and Wires Requirement

Models	MPPT-30A	MPPT-40A	MPPT-50A	MPPT-60A
Copper wires	6mm ²	6mm ²	6mm ² x2PCS	6mm ² x2PCS
AWG	#10	#10	#10*2	#10*2
Air circuit breakers	63A	63A	63A	100A

Reminder

For MPPT-30A and MPPT-40A, you can connect one wire to one PV+ and another wire to one PV-.
For MPPT-50A and MPPT-60A, it's better to connect two wires to two PV+ and another two wires to two PV-.
For BAT+ and BAT-, it's same way to connect wires.

- 1. Install air circuit breaker between controller and batteries. Turn off the circuit breaker, then connect batteries to controller with correct polarity.
- 2. Install air circuit breaker between controller and PV modules. Turn off the circuit breaker, and ensure the PV polarity correct, then connect wires between PV modules and controller.
- 3. Turn on the air circuit breaker between controller and batteries.
- 4. Turn on the air circuit breaker between controller and PV modules.
- 5. The controller goes into the self-test mode. Its LCD displays the parameters if all is correct. And RUN lamp (under the fan inside of casing) will flash every one second. If the controller is no response, please read full manual again for reinstalling or contact us for help.

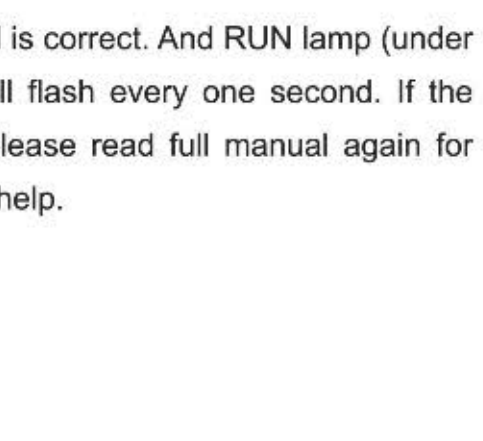

User's manual

6. Operation

6.1 LCD display

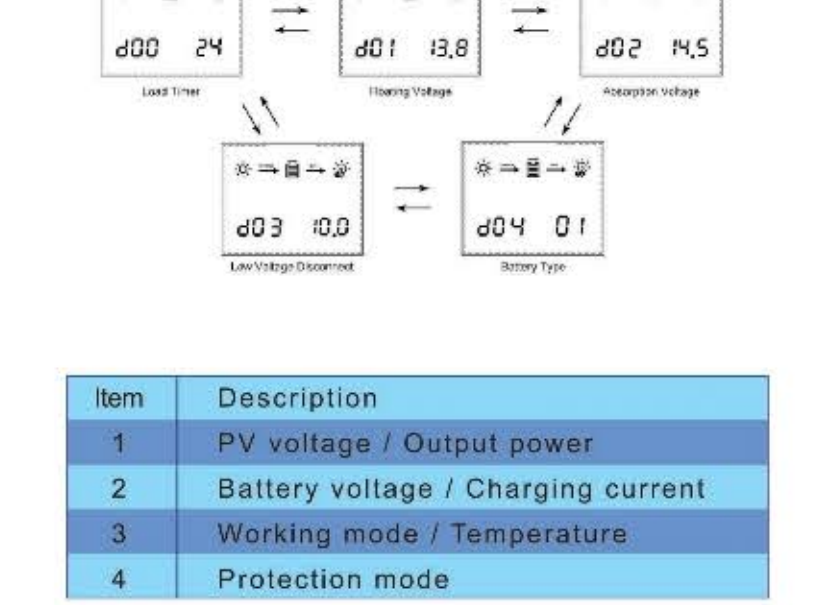

Item	Description
1	PV voltage / Output power
2	Battery voltage / Charging current
3	Working mode / Temperature
4	Protection mode

6.2 Working mode

3.0	NIGHT mode, no charging
4.0	MPPT mode
7.0	Absorption mode
8.0	Float mode

6.3 Batteries charge voltage reference

Battery Type	Absorption Voltage (Constant voltage)			Floating Voltage		
	12V	24V	48V	12V	24V	48V
Vented	14.2V	28.6V	57.2V	13.2V	26.4V	52.80V
Sealed	14.4V	28.8V	57.6V	13.6V	27.6V	55.2V
Gel	14.4V	28.8V	57.6V	13.8V	27.6V	55.2V
LiFePO4	14.2V	28.6V	57.2V	14.0V	28.0V	56.0V
Lithium or others	Defined by users					

6.4 Manual Setting

Reminder: The controller will work fine under default setting except lithium battery.

Caution! All steps must be carried out when the PV modules are disconnected to controller.

Step 1: D00

Press the button PRG, LCD displays D00. This is setting for load working time (Default is 24-hour). Press ENT until numbers flash, then press UP/DOWN to set up time that you want, long-press ENT to confirm it. This output voltage is same as battery. The load is only for small DC loads less 5A current. If no load, just leave it.

Step 5: D04

Continue to press the button UP, LCD shows 00.00 is default for acid batteries. If it's for lithium battery, please press ENT until numbers flash, then press UP/DOWN to set up time that you want, long-press ENT to confirm it. Step 2 (D01) is no useful when you choose 01 for lithium battery. And the voltage set in step 3 (D02) will be highest charging voltage for lithium battery. Press ESC to exit the setting menu.

Reminder: When you set up all steps, please disconnect battery. And reconnect controller to see if all setting is successful. When all setting is ok, then connect PV modules to controller.

User's manual

7. Troubleshooting , Protections

7.1 Protections

① PV Over Current

The controller will limit charging power in rated charge power. An over-sized PV array won't be operated at maximum power point.

② PV Short Circuit

When PV short circuit occurs, the controller will stop charging. Remove it to start normal operation

③ PV Reverse Polarity

Fullly protection against PV connection to start normal operation. The controller correct the connection to start normal operation.

④ Battery Over Voltage

If there are other energy sources to charge the battery, when the battery voltage exceeds 15.5/31.0/46.5/62.0V, the controller will stop charging to protect the battery from overcharging damage. (Pay attention to the stop charging means charging current is very low)

⑤ Battery Over Discharge

When battery voltage drops to the setting voltage point of low voltage disconnect, the controller will stop charging to protect the battery from over discharging damage.

⑥ Load Over Current protection

If the load current exceeds the maximum load current rating 1.25 times, the controller will disconnect the load.

7.2 Troubleshooting

Code	Description	How to solve
18	Input PV voltage is low	Increase the PV voltage
60	Over-temperature protection	Fan will work and temperature reduction automatically
63	Battery voltage is high	Battery high voltage protection and wait for recovery
65	Battery voltage is low	Battery over-discharge and wait for recovery
71	Input PV voltage is high	Decrease the PV voltage
73	Over-charging current	Decrease the PV power

⑦ Load Short Circuit Protection

Once the load short circuit happens, the Load Short circuit protection will start automatically.

⑧ Over Temperature Protection

8. Technical Data

Models	MPPT-30A	MPPT-40A	MPPT-50A	MPPT-60A
Charging mode	3-stage: constant current (MPPT), constant voltage, floating			
MAX PV Input Power	12V system	380W	480W	720W
	24V system	720W	960W	1440W
	36V system	1080W	1400W	2100W
	48V system	1440W	1700W	2800W
Input specification DC	12V system DC	20V~80V	20V~80V	20V~80V
	24V system DC	37V~105V	37V~105V	37V~105V
	36V system DC	50V~160V	50V~160V	50V~160V
	48V system DC	72V~160V	72V~160V	72V~160V
Battery voltage automatic recognition: 12V Battery	DC29V~DC15V			
Battery voltage automatic recognition: 24V Battery	DC18V~DC9V			
Battery voltage automatic recognition: 36V Battery	DC30V~DC9V			
Battery voltage automatic recognition: 48V Battery	DC40V~DC9V			
Overcharging protection voltage	15V	30V	45V	60V
Limited current protection	31A	42A	51A	61A
Max efficiency	≥98.1%			
PV utilization	≥99%			

User's manual

Protection function	
Temperature protection	75°C / 167°F
Fan-on temperature	>45°C / 113°F
Fan-off temperature	<40°C / 104°F
Properties	
Size (mm) / Size(in)	214x115x50 / 8.43x4.53x1.97
Net weight(Kg) / Net weight(lb)	1.1 / 2.43
Gross weight(Kg) / Gross weight(lb)	1.2 / 2.65
Electromagnetic compatibility	Accord to EN61000, EN55022, EN55024
Enclosure	IP21
Environmental temperature	-20°C ~ +55°C / -4°F ~ +122°F
Storage temperature	-40°C ~ +75°C / -40°F ~ +167°F

9. Content Included

- 1X MPPT Solar Charge Controller
- 1X English manual
- 4X Corner connections
- 4X Screws for controller casing

User's manual

Application form for returns / exchanges

Purchase information	
Name	Contact number
Purchase Date	Purchase channels
Order Number	Buyer ID
Email address	
Returns / exchanges information	
Application for return date	
Product fault description	
Processing options	<input type="checkbox"/> Return <input type="checkbox"/> Exchanges <input type="checkbox"/> Repair

User's manual

Protection function	
Temperature protection	75°C / 167°F
Fan-on temperature	>45°C / 113°F
Fan-off temperature	<40°C / 104°F
Properties	
Size (mm) / Size(in)	214x115x50 / 8.43x4.53x1.97
Net weight(Kg) / Net weight(lb)	1.1 / 2.43
Gross weight(Kg) / Gross weight(lb)	1.2 / 2.65
Electromagnetic compatibility	Accord to EN61000, EN55022, EN55024
Enclosure	IP21
Environmental temperature	-20°C ~ +55°C / -4°F ~ +122°F
Storage temperature	-40°C ~ +75°C / -40°F ~ +167°F

9. Content Included

- 1X MPPT Solar Charge Controller
- 1X English manual
- 4X Corner connections
- 4X Screws for controller casing